

SDS ULTRA

DIMENSIONAL SPECIFICATIONS

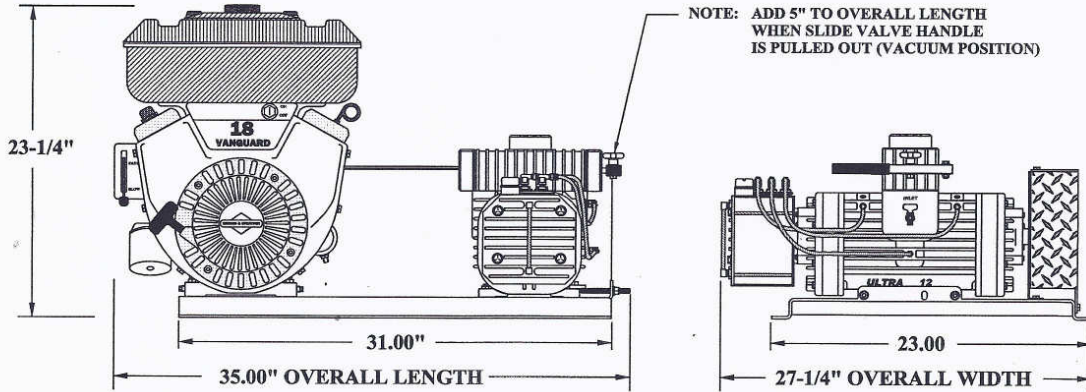

| PART NO. | OLUN12SDSULT18 | HDUN12SDSULT18 |
|----------------------|----------------|----------------|
| CFM, FA DISPLACEMENT | 230 | 230 |
| CFM @ 15" HG | 94 | 94 |
| HORSEPOWER | 18 | 18 |
| BRIGGS & STRATTON | ELECTRIC START | ELECTRIC START |
| VACUUM/PRESSURE | NO | YES |
| VACUUM ONLY | YES | NO |
| MAXIMUM VACUUM | 27" HG | 27" HG |
| MAXIMUM PRESSURE* | 15 PSIG | 15 PSIG |
| WEIGHT | 340 | 347 |
| OILER | AUTOMATIC | AUTOMATIC |

* CONDE PUMPS RECOMMENDS THAT PRESSURES ON TANK SYSTEMS DO NOT EXCEED 10 PSI.
 A PRESSURE RELIEF VALVE IS REQUIRED (SET NOT TO EXCEED 10 PSI).
 PRESSURE VENT ON PUMP WILL RELIEF TANK PRESSURE WHEN UNIT IS OFF.

PERFORMANCE SPECIFICATIONS

| TANK SIZE | #12 SDS ULTRA, 18 HP |
|--------------|----------------------|
| 500 GALLONS | 12 SECONDS |
| 750 GALLONS | 18 SECONDS |
| 1000 GALLONS | 24 SECONDS |
| 1500 GALLONS | 36 SECONDS |
| 2000 GALLONS | 47 SECONDS |

CONDE' PUMPS

WESTMOOR LTD
 906 WEST HAMILTON AVE
 SHERRILL, NEW YORK 13461

PHONE: 800-367-0972, 315-363-1500
 FAX: 315-363-0193
 E-MAIL: pumps@westmoorltd.com

SDS 12

DIMENSIONAL SPECIFICATIONS

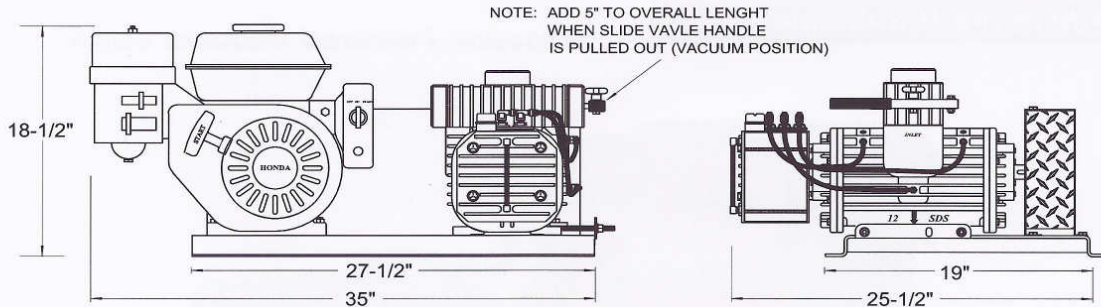

TECHNICAL SPECIFICATIONS

| Part No. | OLUN12SDS13E | HDUN12SDS13E |
|-------------------|--------------|--------------|
| CFM, FREE AIR | 180 | 180 |
| CFM, 15" Hg | 90 | 90 |
| Horsepower | 13 | 13 |
| Honda El. Start | YES | YES |
| Vacuum/Pressure | NO | YES |
| Vacuum Only | YES | NO |
| Maximum Vacuum | 27" Hg | 27" Hg |
| Maximum Pressure* | 15 PSIG | 15 PSIG |
| Weight | 270 Lbs. | 275 Lbs. |
| Oiler | Automatic | Automatic |

* Conde Pumps recommends that pressures on tank systems do not exceed 10 psi. Unit pressure relief vents are set at 5 to 10 psig. Pressure vents will relieve tank pressure when unit is shut off. For higher pressures consult factory.

PERFORMANCE SPECIFICATIONS

Tank Pull Down Time to 15" Hg

| TANK SIZE | SDS 12, 13 HP |
|--------------|---------------|
| 500 gallons | 14 sec. |
| 750 gallons | 21 sec. |
| 1000 gallons | 28 sec. |
| 1500 gallons | 42 sec. |
| 2000 gallons | 56 sec. |

Conde' Pumps

Westmoor Ltd.

906 West Hamilton Avenue
P.O. Box 99
Sherrill, New York 13461

Phone: 800-367-0972, 315-363-1500

Fax: 315-363-0193

E-Mail: pumps@westmoorltd.com

SDS 6

DIMENSIONAL SPECIFICATIONS

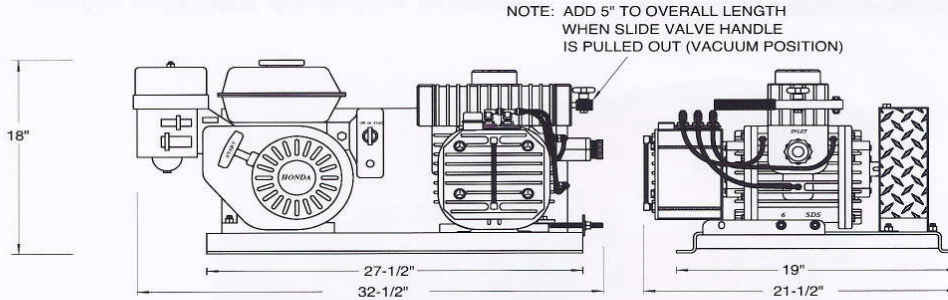

TECHNICAL SPECIFICATIONS

| Part No. | OLUN06SDS09ES | HDUN06SDS09ES |
|-------------------|---------------|---------------|
| CFM, FREE AIR | 115 | 115 |
| CFM, 15" Hg | 55 | 55 |
| Horsepower | 9.0 | 9.0 |
| Honda El. Start | YES | YES |
| Vacuum/Pressure | NO | YES |
| Vacuum Only | YES | NO |
| Maximum Vacuum | 27" Hg | 27" Hg |
| Maximum Pressure* | 15 PSIG | 15 PSIG |
| Weight | 195 Lbs. | 200 Lbs. |
| Oiler | Automatic | Automatic |

* Conde Pumps recommends that pressures on tank systems do not exceed 10 psi. Unit pressure relief vents are set at 5 to 10 psig. Pressure vents will relief tank pressure when unit is shut off. For higher pressures consult factory.

PERFORMANCE SPECIFICATIONS

Tank Pull Down Time to 15" Hg

| TANK SIZE | SDS 6, 9.0 HP |
|--------------|---------------|
| 500 gallons | 23 sec. |
| 750 gallons | 35 sec. |
| 1000 gallons | 47 sec. |
| 1500 gallons | 70 sec. |
| 2000 gallons | 93 sec. |

Conde' Pumps

Westmoor Ltd.

906 West Hamilton Avenue
P.O. Box 99
Sherrill, New York 13461

Phone: 800-367-0972, 315-363-1500

Fax: 315-363-0193

E-Mail: pumps@westmoortd.com

SUPER 6

DIMENSIONAL SPECIFICATIONS

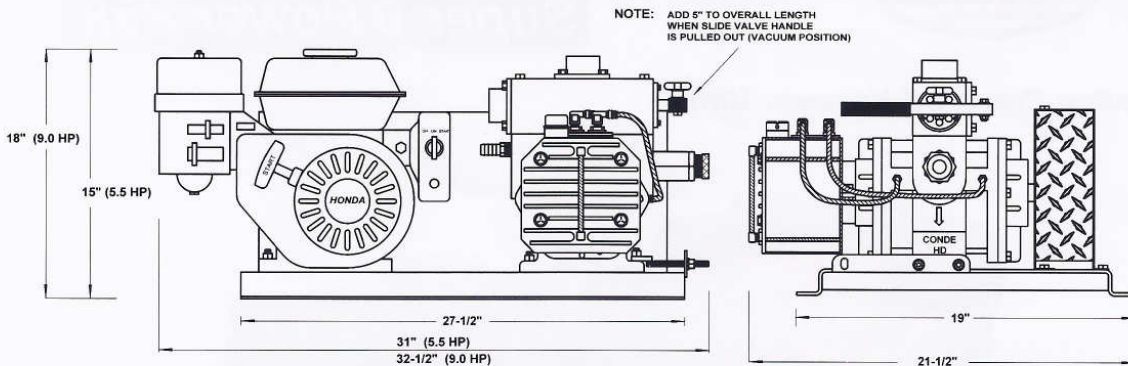

03/29/04
#6 SUPER - 5.5 HP HONDA ELECTRIC START UNIT

TECHNICAL SPECIFICATIONS

| Part No. | OLUN06SS05ES | HDUN06SS05ES |
|-------------------|--------------|--------------|
| CFM, FREE AIR | 60 | 60 |
| CFM, 15" Hg | 35 | 35 |
| Horsepower | 5.5 | 5.5 |
| Honda El. Start | YES | YES |
| Vacuum/Pressure | NO | YES |
| Vacuum Only | YES | NO |
| Maximum Vacuum | 27" Hg | 27" Hg |
| Maximum Pressure* | 15 PSIG | 15 PSIG |
| Weight | 155 Lbs. | 160 Lbs. |
| Oiler | Automatic | Automatic |

* Conde Pumps recommends that pressures on tank systems do not exceed 10 psi. Unit pressure relief vents are set at 5 to 10 psig. Pressure vents will relieve tank pressure when unit is shut off. For higher pressures consult factory.

PERFORMANCE SPECIFICATIONS

Tank Pull Down Time to 15" Hg

| TANK SIZE | Super 6, 5.5 HP | Super 6, 9.0 HP |
|--------------|-----------------|-----------------|
| 500 gallons | 42 sec. | 33 sec. |
| 750 gallons | 63 sec. | 50 sec. |
| 1000 gallons | 83 sec. | 67 sec. |
| 1500 gallons | 125 sec. | 100 sec. |
| 2000 gallons | 165 sec. | 133 sec. |

Conde' Pumps

Westmoor Ltd.

906 West Hamilton Avenue
P.O. Box 99
Sherrill, New York 13461

Phone: 800-367-0972, 315-363-1500

Fax: 315-363-0193

E-Mail: pumps@westmoorltd.com

PROVAC 3

DIMENSIONAL SPECIFICATIONS

CONDE' #3 HD PROVAC GAS UNIT DIMENTIONAL SPECIFICATIONS

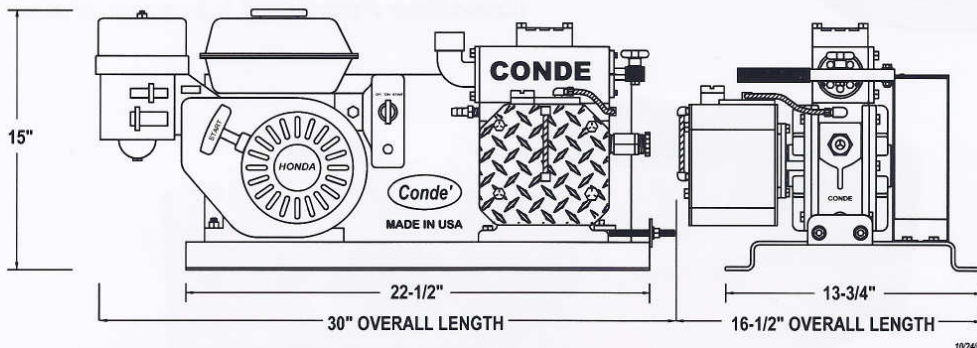

TECHNICAL SPECIFICATIONS

| Part No. | OLUN03PV3PS | OLUN03PV05ES |
|-------------------|-------------|--------------|
| CFM, FREE AIR | 35 | 35 |
| CFM, 15" Hg | 17 | 17 |
| Horsepower | 3.0 | 5.5 |
| Honda El. Start | NO | YES |
| Vacuum/Pressure | NO | NO |
| Vacuum Only | YES | YES |
| Maximum Vacuum | 27" Hg | 27" Hg |
| Maximum Pressure* | 15 PSIG | 15 PSIG |
| Weight | 100 Lbs. | 125 Lbs. |
| Oiler | Automatic | Automatic |

* Conde Pumps recommends that pressures on tank systems do not exceed 10 psi. Unit pressure relief vents are set at 5 to 10 psig. Pressure vents will relieve tank pressure when unit is shut off. For higher pressures consult factory.

PERFORMANCE SPECIFICATIONS

Tank Pull Down Time to 15" Hg

| TANK SIZE | Model 3 Unit |
|-------------|--------------|
| 60 gallons | 12 sec. |
| 200 gallons | 40 sec. |
| 300 gallons | 60 sec. |

Conde' Pumps

Westmoor Ltd.

906 West Hamilton Avenue
P.O. Box 99
Sherrill, New York 13461

Phone: 800-367-0972, 315-363-1500

Fax: 315-363-0193

E-Mail: pumps@westmoortld.com